

Applied

Grade 9 Assessment of Mathematics

Winter 2008

SAMPLE ASSESSMENT QUESTIONS

**Record your answers to the multiple-choice questions
on the blank Student Answer Sheet (Winter 2008, Applied).**

Education Quality and
Accountability Office



Please note: The format of these booklets is slightly different from that used for the assessment. The items themselves remain the same.

- 1** A carton that holds 500 mL of chocolate milk costs \$2.29.
Which of the following containers has a lower cost per mL?
- a 250 mL at \$1.29
 - b 700 mL at \$3.09
 - c 750 mL at \$3.59
 - d 1000 mL at \$4.69
- 2** Which of the following fractions is **not** equivalent to $\frac{10}{30}$?
- a $\frac{2}{6}$
 - b $\frac{15}{35}$
 - c $\frac{1}{3}$
 - d $\frac{100}{300}$
- 3** Aidan is buying a new CD player. The CD player was selling for \$84.79 and now is on sale for 25% off. Which of the following is closest to the total cost of the CD player, including 15% sales tax?
- a \$54.05
 - b \$63.59
 - c \$73.13
 - d \$74.49

- 4** What is the value of the expression $-1 + \frac{77}{100}$?
- a $-\frac{177}{100}$
 - b $-\frac{78}{100}$
 - c $-\frac{76}{100}$
 - d $-\frac{23}{100}$

- 5** The volume of a cylinder is 325 cm^3 . The height is 8.5 cm.
Which is closest to the measure of the radius?

Hint: $V = \pi r^2 h$

- a 3.49 cm
 - b 6.09 cm
 - c 12.17 cm
 - d 38.24 cm
- 6** What is the solution to the equation $3x + 80 = 12x - 1$?
- a -27
 - b -9
 - c 9
 - d 27

7 Field Maintenance

A field in the shape of a trapezoid has a perimeter of 460 m. A fence is being built along the field's perimeter.

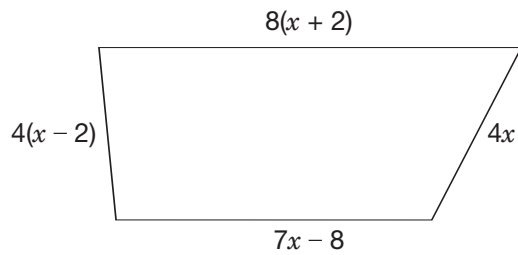

Determine the length of fencing needed for each side of the field.

Show your work.



- 8** Mia delivers the local newspaper. Her base pay is \$5 per week, and she gets \$0.25 per paper.

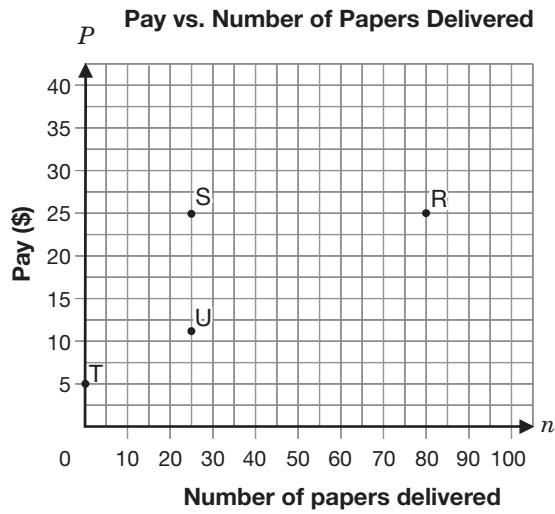

Which of the points on the graph represents Mia's pay for delivering 25 newspapers in a week?

- a Point R
- b Point S
- c Point T
- d Point U

- 9** Which of the following graphs represents a linear relation?

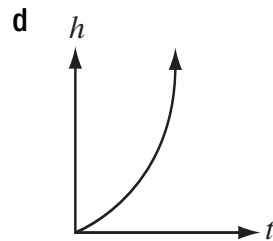
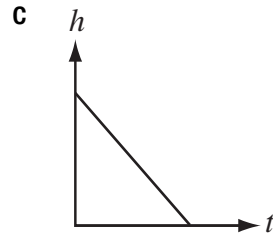
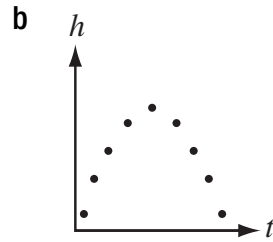
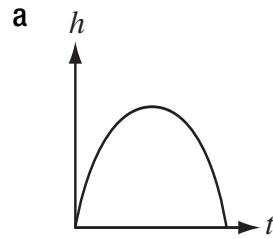

- 10** Simon records the height of a plant each day for five days.

**Plant Growth Over
Five Days**

Day	Height (cm)
0	4
1	5
2	7
3	10
4	14

His chart shows that the relation between height and day

- a** is a linear relation.
b is a non-linear relation.
c has a constant rate of change.
d has a decreasing rate of change.

- 11** Victoria is selling chocolate bars to raise money for her hockey team. She begins with 36 bars to sell and sells four bars per day.

Which of the following represents the relation between N , the number of chocolate bars remaining, and d , the number of days she has been selling?

- a** $N = 36 + 4d$
b $N = 36d - 4$

c

Day, d	Number of bars remaining, N	First differences
0	20	
1	24	4
2	28	4
3	32	4
4	36	4

d

Day, d	Number of bars remaining, N	First differences
0	36	
1	32	-4
2	28	-4
3	24	-4
4	20	-4

- 12** Tyler belongs to a fitness club at the community centre. The graph below represents the relationship between the number of times he visits the club and his total monthly cost.

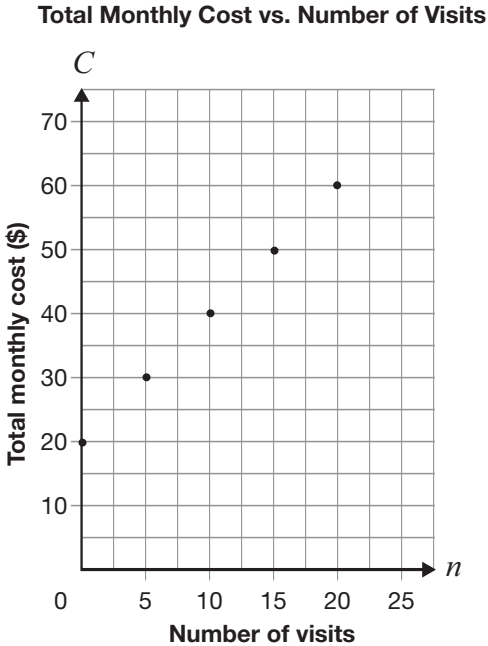

What type of variation is this relationship, and what is the initial value?

- a Direct variation, and initial value is 0
- b Partial variation, and initial value is 0
- c Direct variation, and initial value is 20
- d Partial variation, and initial value is 20

- 13** A tap is leaking into a pail. The height of the water in the pail is represented by the equation $h = 0.5t + 2$, where h represents the height of water in the pail, in cm, and t represents the amount of time the tap has been leaking, in minutes.

What is the height of water in the pail if the tap has been leaking for 56 minutes?

- a 28 cm
- b 30 cm
- c 108 cm
- d 114 cm



- 14** The relationship between t , the number of minutes Shufrah travels, and D , the distance she is from home, is shown on the grid below.

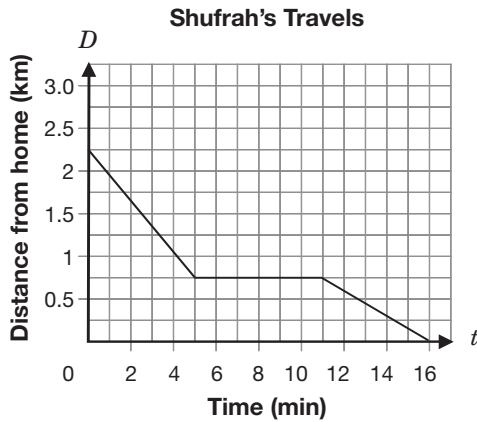

Which of the following statements best describes the way Shufrah travels?

- a While travelling toward her home, Shufrah rides her bike, stops and then walks.
- b While travelling toward her home, Shufrah rides her bike, walks and then rides her bike.
- c While travelling away from home, Shufrah rides her bike, stops and then walks.
- d While travelling away from home, Shufrah walks, rides her bike and then walks.



15 Makin' a Profit!

Student council is planning a dance.

- The cost to hire a DJ is \$300.
- Tickets are sold at \$6 each.
- The profit is based on the amount received from the tickets sold minus the cost of the DJ.

Complete the table of values to show the profit based on the number of tickets sold.

Profit from Ticket Sales

Number of tickets sold	Profit (\$)
0	
50	
100	
150	
200	

Graph these data on the grid below.

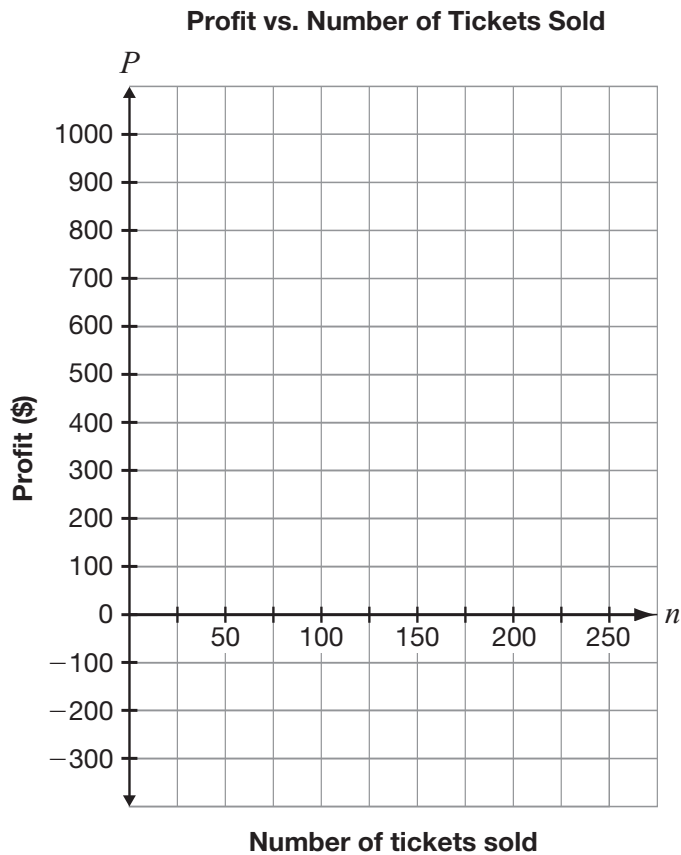

16 Rockin' Radicals

The Radicals, a small high school band, recently signed a contract with a record label. Their earnings include a signing bonus plus an amount per CD sold, as shown in the table below.

Number of CDs	Band earnings (\$)
0	10 000
5 000	10 600
10 000	11 200
15 000	11 800
20 000	12 400

Determine the amount of the signing bonus and the amount they receive per CD.

Show your work.



- 17** Germaine wants to calculate the area of the shape shown below. It is composed of a rectangle and two semicircles.



Which of the following pairs of expressions should Germaine use to determine the area of the shape?

- a $2(l + w), \pi r^2$
 - b $2(l + w), 2\pi r$
 - c $lw, 2\pi r$
 - d $lw, \pi r^2$
- 18** Silvia is making lemonade. She is using a cylindrical container with a radius of 10 cm and a height of 30 cm, as shown below.

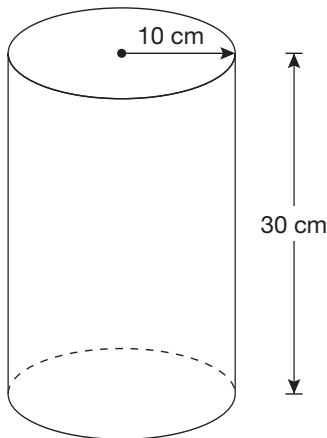

Which of the following is closest to the volume of the container?

- a 37 700 cm³
- b 9425 cm³
- c 1885 cm³
- d 600 cm³

- 19** A soccer ball is packaged in a cube-shaped box.

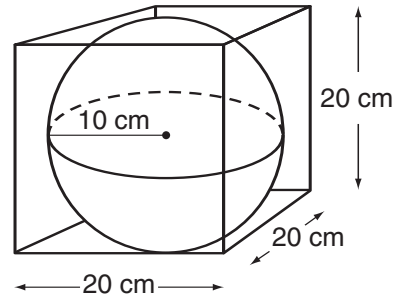

Which is closest to the volume of the space in the package that is **not** occupied by the ball?

- a 3811 cm³
 - b 4000 cm³
 - c 4187 cm³
 - d 8000 cm³
- 20** The measure of $\angle ACB$ is 39° .

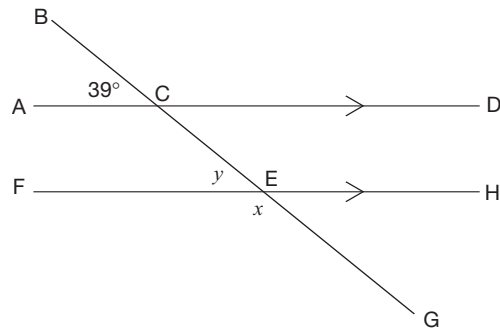

What are the values of x and y ?

- a $x = 39^\circ$ and $y = 141^\circ$
- b $x = 39^\circ$ and $y = 39^\circ$
- c $x = 141^\circ$ and $y = 141^\circ$
- d $x = 141^\circ$ and $y = 39^\circ$

21 Paint

Jackson is buying paint for his wall.

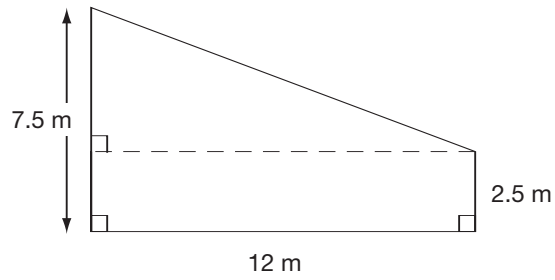

One litre of paint will cover 9 m^2 .

How many litres of paint does he need to cover the wall?

Justify your answer.

**Education Quality and
Accountability Office**



2 Carlton Street, Suite 1200, Toronto ON M5B 2M9

Telephone: 1-888-327-7377 Web site: www.eqao.com

© 2008 Queen's Printer for Ontario