

Design Elements & Principles

I. Introduction

Certain web sites seize users' sights more easily, while others don't. Why?

Sometimes we have to remark our opinion about likes or dislikes of web sites, and it is easy to say just "I like this, or I don't like that..." But if we are asked to answer the question why, then it is very difficult to find out the reason.

Which factors do influence on someone to have a certain attitude toward a web page? There may be very many reasons related to it, but I think the 'design' of the web page is the very critical one of them.

I will describe the elements and principles of design and by doing so I want to articulate the sub-factors of design that have influence on the users' attitude toward a web site in this article.

II. Significance of the topic

Even though not comprehensive and elaborated, the design elements and principles described here can be an analyzing frame for web page design. They can inform us where to begin, what to probe, and how to analyze. For example designer who knows the design elements and principles can analyze the page in terms of line, color, movements, balance, harmony, and so forth, while others are just thinking that it is appealing for them or not.

This information can also give an expressing tool to the web designer. A novelist can express his or her thought using language. A web page designer also expresses their thought or a certain intention with elements of design and does it effectively along with the design principles. If a designer want to say something through the web page, than he must use the elements (line, color, etc) as a communication tool. So it is very important to know the kinds and meanings of the design elements and principles.

Although color is one of the most important design elements, but I excluded the detail description of it, because color-related subject has already seized designers' interests and many designers, I think, already know of it very much.

III. Design Elements

The elements are components or parts which can be isolated and defined in any visual design or work of art. They are the structure of the work, and can carry a wide variety of messages. The details may be differentiated by researchers, but I included 'point or mark', 'line', 'shape', 'forms', 'space', 'color', and 'texture' in this article.

A. Point or Mark

A point or mark is the smallest and most basic element. Often it is the personal 'handwriting' of the artist that can be natural or learned. These can vary in size, value, regularity or irregularity, and can be used alone or as a unit in a group which forms a line or shape in the image. Marks can be used to form a value or pattern (placed close together forms a darker value, further apart forms a lighter value), or to delineate space (larger

means closer, etc.). A good example of the use of marks is the ink drawings of Van Gogh. The Impressionist painters used what could be called patches; and the Pointillists, such as Seurat, used the dot.

Even though there is only one point or mark on a white blank page, it can catch our sight. If there are two points, we will make a connection and see a line. If there are three points, it is unavoidable to interpret them as a triangle; the mind supplies the connections. These are called as grouping, or gestalt. Gestalt is the fundamental tool the designer or artist uses to build a coherent composition.

B. Line

A line is a form with width and length, but no depth. Artists use lines to create edges, the outlines of objects. A line is created by the movement of the artist's pen.

The direction of a line can convey mood. Horizontal lines are calm and quiet, vertical lines suggest more of a potential for movement, while diagonal lines strongly suggest movement and give more of a feeling of vitality to a picture.

C. Shape

Shape is an area that is contained within implied line, or is seen and identified because of color or value changes. Shapes have two dimensions, length and width, and can be geometric or free-form. Design in painting is basically the planned arrangement of shapes in a work of art.

In a picture, the shapes that the artist has placed are considered the positive shapes. The spaces around the shapes are the negative spaces. It is just as important to consider the negative space in a picture as the positive shapes.

D. Forms

Form describes volume and mass, or the three dimensional aspects of objects that take up space. (Shape is two-dimensional) Forms can and should be viewed from any angles. When you hold a baseball, shoe, or small sculpture, you are aware of their curves, angles, indentations, extensions, and edges---their forms.

E. Space

Actual space is three-dimensional volume that can be empty or filled with objects. It has width, height, and depth. Space that appears three-dimensional in a two-dimensional painting is an illusion that creates a *feeling* of actual depth. Various techniques can be used to show such visual depth or space.

F. Color

Color has three properties. The first is hue, which is the name of the colors. The primary hues are yellow, red, and blue. Secondary colors are made by mixing two primaries. Intermediate colors are mixtures of a primary and adjacent secondary color.

The second property of color is value, which refers to the lightness or darkness of hue. The third property of color is intensity, which refers to the purity of the hue (also called "chroma").

G. Texture

Texture refers to the surface quality, both simulated and actual, of artwork.

Techniques used in painting serve to show texture, i.e. the dry brush technique produces a rough *simulated* quality and heavy application of pigment with brush or other implement produces a rough *actual* quality.

IV. Design Principles

A. Balance

Balance is a psychological sense of equilibrium. As a design principle, balance places the parts of a visual in an aesthetically pleasing arrangement. In visual images, balance is formal when both sides are symmetrical in terms of arrangement. Balance is informal when sides are not exactly symmetrical, but the resulting image is still balanced. Informal balance is more dynamic than formal balance and normally keeps the learner's attention focused on the visual message. There are three main types of balance, horizontal balance, vertical balance, radial balance.

B. Proportion

Proportion refers to the relative size and scale of the various elements in a design. The issue is the relationship between objects, or parts, of a whole. This means that it is necessary to discuss proportion in terms of the context or standard used to determine proportions.

C. Perspective

Perspective is created through the arrangement of objects in two-dimensional space to look like they appear in real life. Perspective is a learned meaning of the relationship between different objects seen in space.

Is the dark rectangle in front of a circle, or beside a semi-circle? Perspective adds realism to a visual image. The size of a rectangle means little until another object gives it the size of a desk, or the size of a building. Perspective can be used to draw the audience into a visual. Perception can be achieved through the use of relative sizes of objects, overlapping objects, and blurring or sharpening objects.

D. Emphasis

Emphasis is used by artists to create dominance and focus in their work. Artists can emphasize color, value, shapes, or other art elements to achieve dominance. Various kinds of contrast can be used to emphasize a center of interest.

E. Movement

The way the artist leads the eye in, around, and through a composition. The path the eye follows. Motion or movement in a visual image occurs when objects seem to be moving in a visual image. Movement in a visual image comes from the kinds of shapes, forms, lines, and curves that are used.

F. Pattern

Pattern uses the art elements in planned or random repetition to enhance surfaces or paintings or sculptures. Patterns often occur in nature, and artists use similar repeated motifs to create pattern in their work. Pattern increases visual excitement by enriching surface interest.

G. Repetition

Repetition works with pattern to make the artwork seem active. The repetition of elements of design creates unity within the artwork.

H. Rhythm

Rhythm is the repetition of visual movement of the elements—colors, shapes, lines, values, forms, spaces, and textures. Variety is essential to keep rhythms exciting and active, and to avoid monotony. Movement and rhythm work together to create the visual equivalent of a musical beat.

I. Variety

Variety provides contrast to harmony and unity. Variety consists of the differences in objects that add interest to a visual image. Variety can be achieved by using opposites or strong contrasts. Changing the size, point of view, and angle of a single object can add variety and interest to a visual image.

Breaking a repeating pattern can enliven a visual image.

J. Harmony

Harmony in visual design means all parts of the visual image relate to and complement each other. Harmony pulls the pieces of a visual image together. Harmony can be achieved through repetition and rhythm. Repetition reemphasizes visual units, connecting parts and creating an area of attention. Rhythm is the flow depicted in a visual. Rhythm helps direct eye movement.

Patterns or shapes can help achieve harmony.

By repeating patterns in an interesting arrangement, the overall visual image comes together.

K. Unity

Unity means the harmony of the whole composition. The parts of a composition made to work together as a total visual theme.

Unity is the relationship among the elements of a visual that helps all the elements function together. Unity gives a sense of oneness to a visual image. In other words, the words and the images work together to create meaning.

V. Summary

Elements of design described here are point, line, shape, form, space, color, and texture. And I gathered information about various design principles, like the balance, proportion, perspective, emphasis, movement, pattern, repetition, rhythm, variety, harmony, and unity. These elements and principles can be the basic knowledge and

analytical frame work for a designer. I attached the examples of the elements and principles in appendix. I hope it would be helpful for readers to understand this paper.

References and Related Links

Web design for instruction

<http://www.usask.ca/education/coursework/skaalid/textindex.htm>

Design elements

<http://www.artdesignstudio.com/design.htm>

Elements & Principles of Design

<http://www.ets.uidaho.edu/4-H/kidspace/E-P.htm>

Design IV: Pictorial Elements

<http://www.ndoylefineart.com/design3.html>

<http://www.ndoylefineart.com/design4.html>

The Language of Design

<http://char.txa.cornell.edu/>

The Elements and Principles of Design

http://www.snoqualmie.wednet.edu/schools/ckms/information/curriculum/art/elements_of_design.htm#Value

Interface Hall of Shame - Visual Elements

<http://www.iarchitect.com/visual.htm>

Basic Principles of Landscape Design

http://edis.ifas.ufl.edu/BODY_MG086

The Elements of Design

<http://www.makart.com/resources/artclass/elements.html>

Elements of Design, Principles of Design

<http://www.central-lee.k12.ia.us/FacultyHomePages/lheitz/design.htm>

Design Elements and Principles

<http://vlo.educ.kent.edu/design/index.html>

Color Psychology

<http://www.infoplease.com/spot/colors1.html>

<http://www.losaltosonline.com/latc/arch/9637/FallFash/8color/8color.html>

<http://char.txa.cornell.edu/>

Lesson 4: Presentation Attributes-The Use of Color

<http://web.topchoice.com/~abyers/moduleten/html/lessons/lesson4.htm>

Graphic symbolism

<http://www.wpdfd.com/wpdsymb.htm>

Color symbolism

<http://webdesign.about.com/library/weekly/aa070400a.htm>

This paper is written by Yangjoo Park for the course EDC385G Interactive Multimedia Design &

Production at the University of Texas - Austin

APPENDIX: Examples of design

▪ Design Elements

○ *Line*

- Horizontal lines are calm and quiet

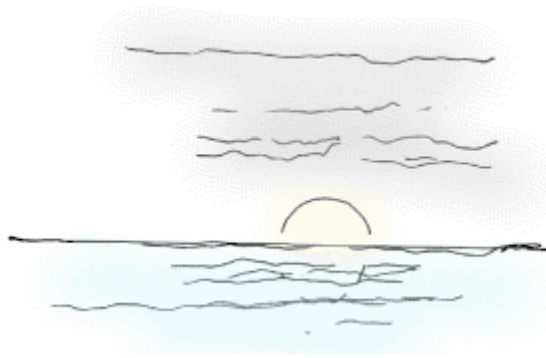

- Vertical lines suggest more of a potential for movement.

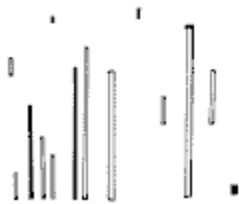

- Diagonal lines strongly suggest movement and give more of a feeling of vitality to a picture.



○ *Shape*

- A shape is defined as an area that stands out from the space next to or around it due to a defined or implied boundary, or because of differences of value, color, or texture.

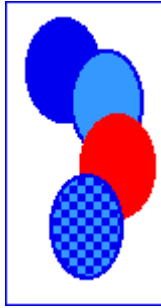

- A shape is formed when a line encloses an area.

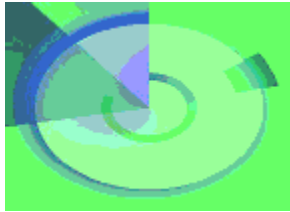

- Shapes can vary endlessly and can suggest physical form and direct eye movement.



- Simple shapes are remembered and understood more easily than complex shapes.

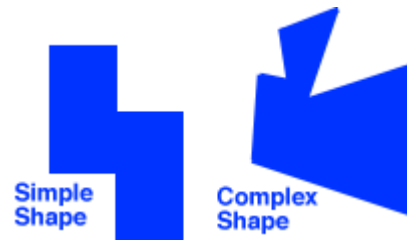

- *Space*

- Size & vertical location

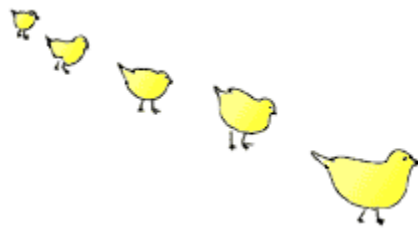

- Overlapping



- Detail (aerial or atmospheric perspectives)



- Linear perspective (converging lines)



○ *Values*

- Value is the relative degree of lightness and darkness in a design element.



- Line, color, texture, and shape all need value contrast in order to be seen.



- Value is used to describe objects, shapes, and space.



- Dark areas tend to denote: gloom, mystery, drama, and menace



- *Texture*



- **Design Principles**

- *Balance*

- Balance is a psychological sense of equilibrium.

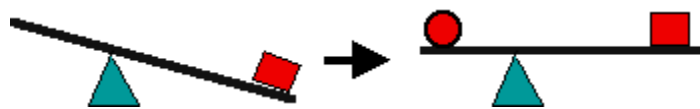

- As a design principle, balance places the parts of a visual in an aesthetically pleasing arrangement.



- In visual images, balance is formal when both sides are symmetrical in terms of arrangement.

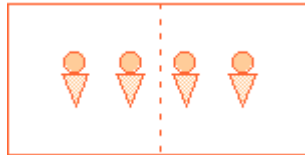

- Balance is informal when sides are not exactly symmetrical, but the resulting image is still balanced.

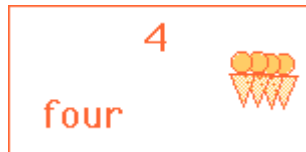

- Informal balance is more dynamic than formal balance and normally keeps the learner's attention focused on the visual message.

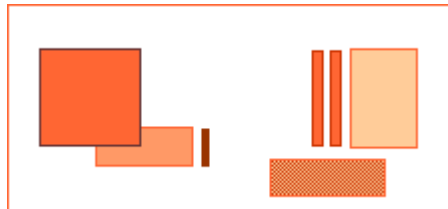

- There are three main types of balance,

horizontal balance, 

vertical balance,

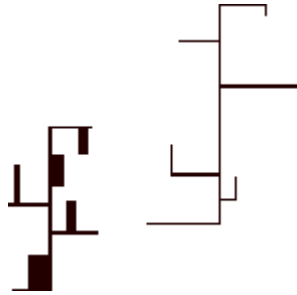

radial balance,

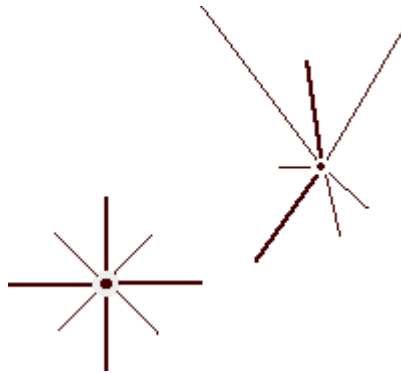

- ***Perspective***

- Perspective is created through the arrangement of objects in two-dimensional space to look like they appear in real life.



- Perspective is a learned meaning of the relationship between different objects seen in space.

Is the dark rectangle in front of a circle,

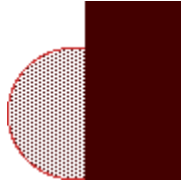

or beside a semi-circle?

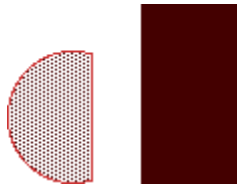

- Perspective adds realism to a visual image. The size of a rectangle means little until another object gives it the size of a desk, or the size of a building.

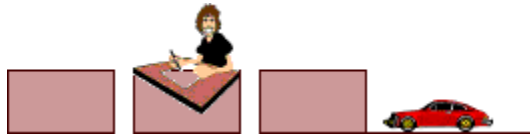

- Perspective can be used to draw the audience into a visual.



- Perception can be achieved through the use of relative sizes of objects,



overlapping objects,

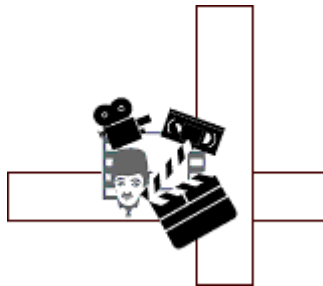

and blurring or sharpening objects.



- ***Movement***

- Motion or movement in a visual image occurs when objects seem to be moving in a visual image.



- Movement in a visual image comes from the kinds of shapes, forms, lines, and curves that are used.



- Diagonal lines tend to create the illusion of movement or motion.



- Similar shapes connected with each other or overlapping each other can imply movement or restlessness.



○ *Emphasis*

- Emphasis by contrast



- Emphasis by isolation

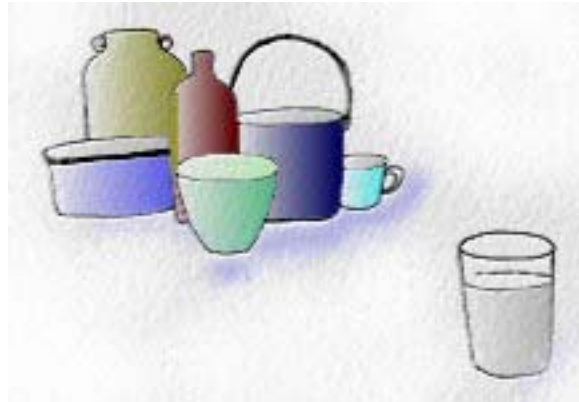

- Emphasis by placement



○ *Variety*

- If this is harmony

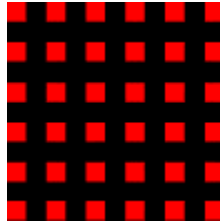

then variety might be something like this.

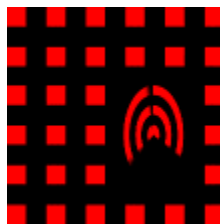

- Variety consists of the differences in objects that add interest to a visual image.

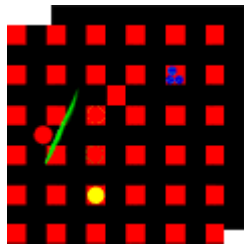

- Variety can be achieved by using opposites or strong contrasts.

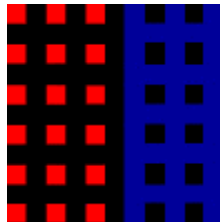

- Changing the size, point of view, and angle of a single object can add variety and interest to a visual image.

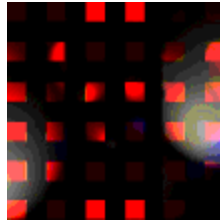

- Breaking a repeating pattern can enliven a visual image.

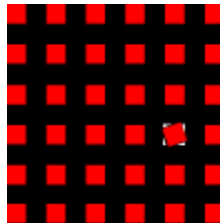

- *Harmony*

- Harmony pulls the pieces of a visual image together.



- Harmony can be achieved through repetition and rhythm.

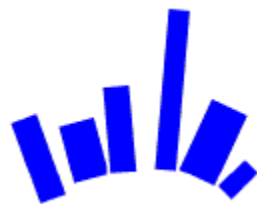

- Patterns or shapes can help achieve harmony.

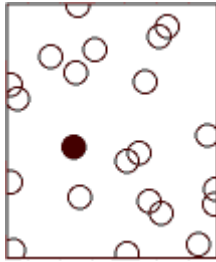

- **Unity**

- Unity is the relationship among the elements of a visual that helps all the elements



- Unity helps organize a visual image, facilitating interpretation and understanding.

This visual is confusing. It is hard to see the relationships between the various parts.

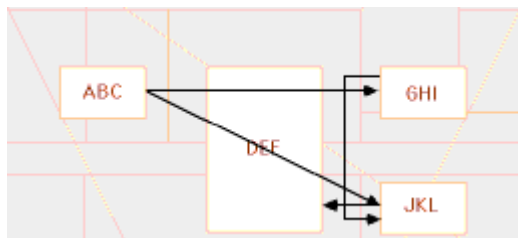

With better unity, the visual is now organized and easier to understand.

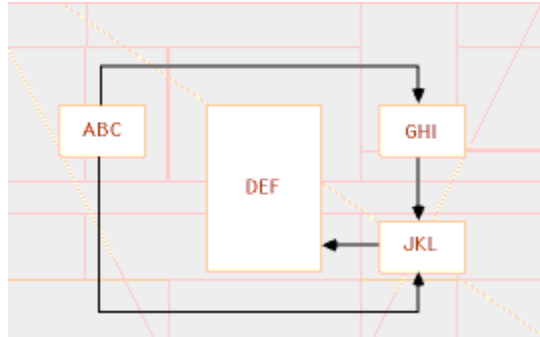

- Unity can be achieved through the use of similar shapes.

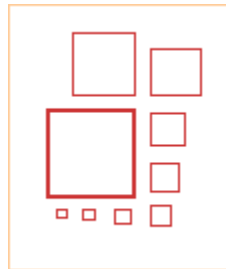

- Unity can be achieved through the use of a common pattern.



- Unity can be achieved through the use of space.



- Unity can be achieved through the use of a common background.

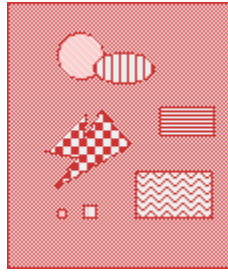

This paper is written by Yangjoo Park for the course EDC385G Interactive Multimedia Design & Production at the University of Texas - Austin